



GREWIN INDUSTRIAL GROUP CO.,LTD.

TEL/WhatsApp: +86 18622096679

Mail: admin@coilwindingmachinechina.com

Web:www.coilwindingmachinechina.com



WhatsApp



WeChat

NAME:GWA-HM09 Inductance Spring Coil Winding Machine



A circular symmetric winding design specifically for the automatic circular and cancel the machine, from the core, into the line, to cancel, blanking devoid of human integrated dual-axis machine, uniaxial around unilateral, cancel the time can be greatly improved, but single layer, two layers of reciprocating, three layers of ribbon cable, wiring, precision, high efficiency, less manpower, wire diameter range wide compatibility, the last more than 2 hours to run core, copper wire whole axial feeding, a man can see more, lack of material (core, copper), shut down automatically after the core is amorphous, iron powder cores, iron, silicon aluminum and so on material, wire can use copper wire, aluminum wire, speed adjustable, convenient and quick change specifications

GREWIN INDUSTRIAL GROUP CO.,LTD.

Add: The fourth floor A-A3 zone aviation business area,Dongli Distr,Tianjin,China.



GREWIN INDUSTRIAL GROUP CO.,LTD.

TEL/WhatsApp: +86 18622096679

Mail: admin@coilwindingmachinechina.com

Web:www.coilwindingmachinechina.com



WhatsApp



WeChat

Wire Length	1600mm
Wire Diameter	0.4-2.2mm
Crochet speed	1-2.5s (The speed varies according to the thickness of the wire diameter)
Core OD	13-50mm (magnetic ring size change needs to replace the fixture)
Core min. ID after finished	The min. wire diameter (0.4mm) is 8mm after completion, and the max. wire diameter (2.0mm) is 15mm after completion
Transition time	7s (Adjust the transition time according to the size of the core)
Main applications	Specially for common mode, differential mode winding
Power	220V/50HZ
Motor	Delta, Panasonic
Circuit switch	Tracy, Chint
Switching power supply	Mingwei
Relay	Omron
Scram switch	Red wave
Aeroelectromagnetism	Airtac, SMC,CKD
Module	Mismi, THK
Atmospheric pressure	6KG
Drive Servo	0.75 KW x 1
Axis Drive Servo	0.4KW
Power Supply	AC + AC 220V

GREWIN INDUSTRIAL GROUP CO.,LTD.

Add: The fourth floor A-A3 zone aviation business area,Dongli Distr,Tianjin,China.



GREWIN INDUSTRIAL GROUP CO.,LTD.

TEL/WhatsApp: +86 18622096679

Mail: admin@coilwindingmachinechina.com

Web:www.coilwindingmachinechina.com



WhatsApp



WeChat

Machine 3D panorama machine dimensions

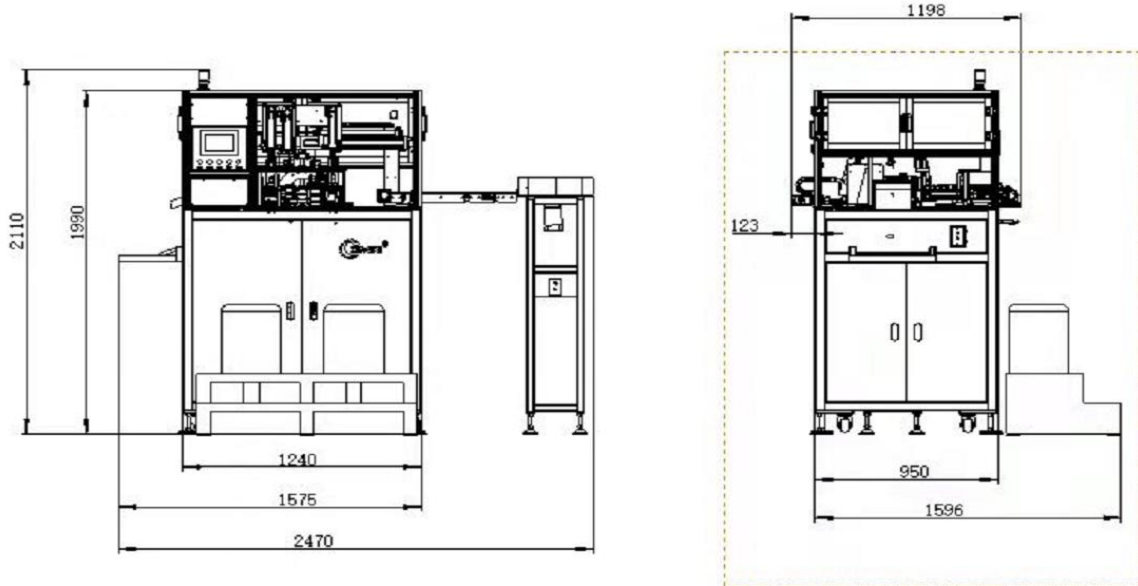

Machine 3D panorama machine dimensions

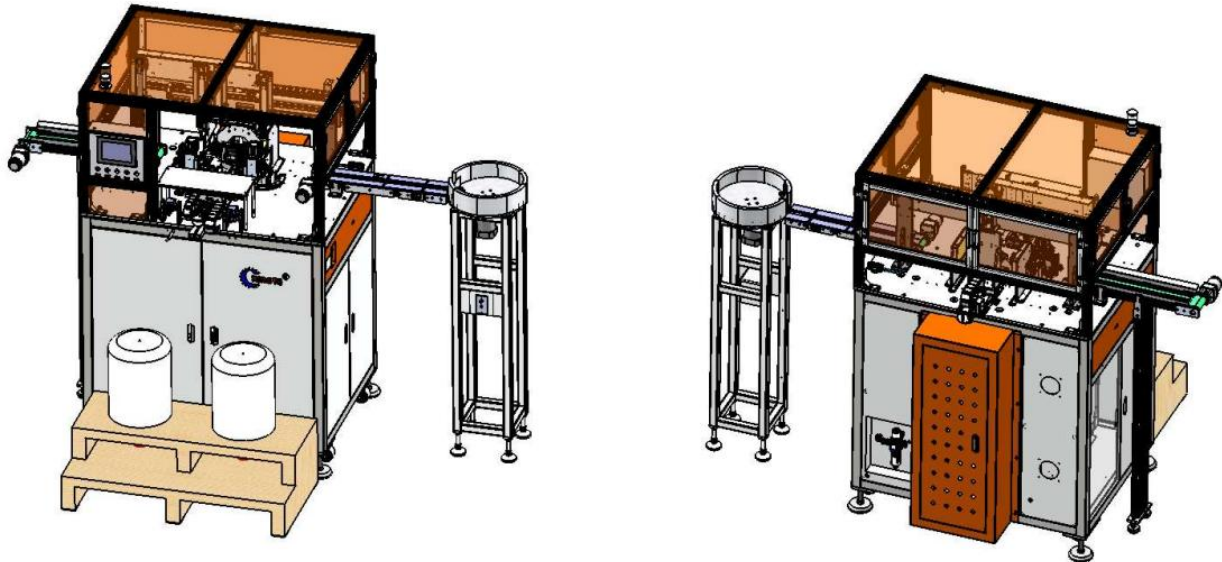

Front perspective of 3D drawing

3D back perspective

GREWIN INDUSTRIAL GROUP CO.,LTD.

Add: The fourth floor A-A3 zone aviation business area,Dongli Distr,Tianjin,China.



GREWIN INDUSTRIAL GROUP CO.,LTD.

TEL/WhatsApp: +86 18622096679

Mail: admin@coilwindingmachinechina.com

Web:www.coilwindingmachinechina.com



WhatsApp



WeChat

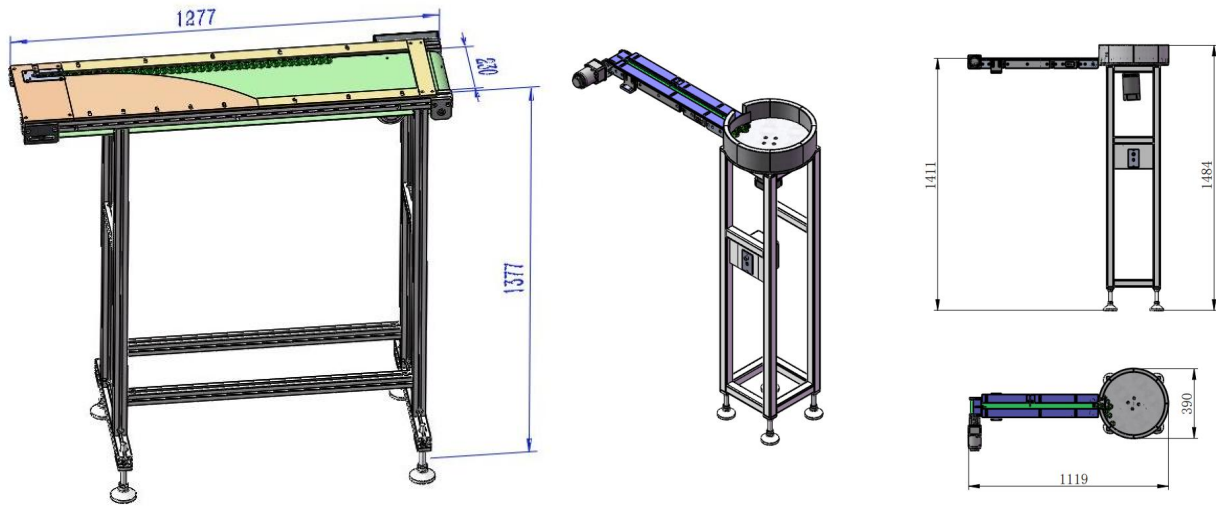

Core flat out on the conveyor belt, the conveyor belt running continuously in the direction of a magnetic core into grooves, sensors detect the magnetic core in place after the conveyor belt to stop, after feeding clip clip core conveyor belt again start signal, in circulation, T30 magnetic cores, for example a conveyor belt can be carrying about 200 core, only 1.5 hours for equipment operation, after there is no material on the conveyor belt device will automatically stop, replacement products can be adjusted the screens on both sides of the groove.

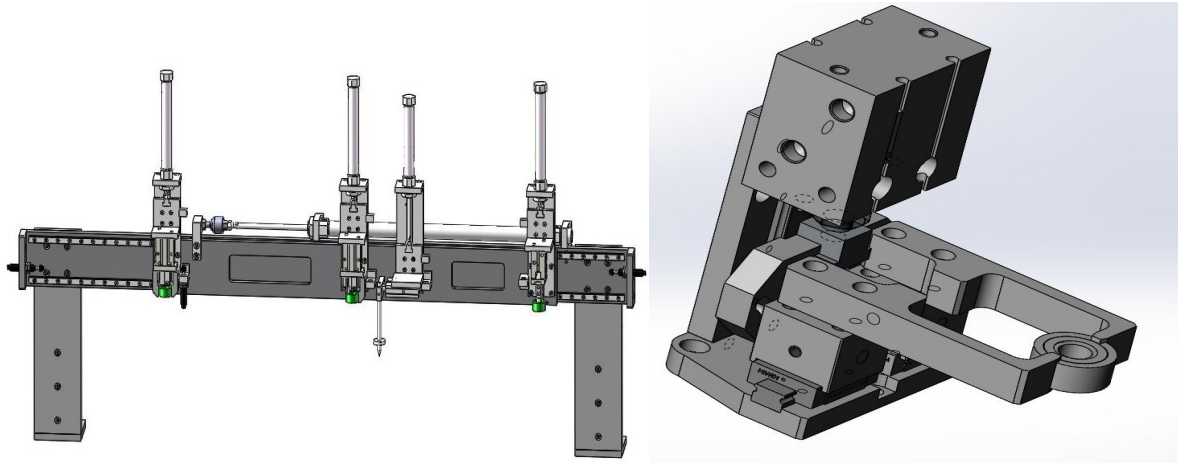

Pneumatic tension tail seat

Load the core structure

The structure of the upper magnetic core is a three-axis linkage combination. The upper magnetic core is used to transfer the single-side wound coil, and the three groups of discharging are integrated. The magnetic core clip is used to clamp both sides to ensure that the two sides are under uniform stress and the magnetic core will not be broken

GREWIN INDUSTRIAL GROUP CO.,LTD.

Add: The fourth floor A-A3 zone aviation business area,Dongli Distr,Tianjin,China.



GREWIN INDUSTRIAL GROUP CO.,LTD.

TEL/WhatsApp: +86 18622096679

Mail: admin@coilwindingmachinechina.com

Web:www.coilwindingmachinechina.com



WhatsApp



WeChat



3D diagram of dual-axis wiring device

The transmission mode is servo motor to XL belt, with precise running without clearance. The transmission mode is magnetic core fixed seat operation, with the maximum running position up to 340°. The line distance running position is set according to the digital Angle, and the Angle of each layer can be set arbitrarily

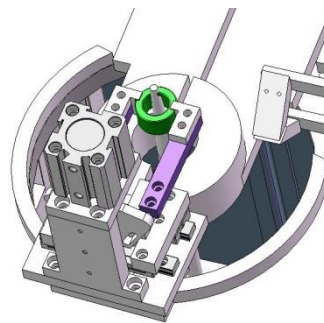

3D drawing of the operation mode

Double crochet hook is connected up and down at the same time. The longest stroke of one side is 850mm for each turn of the equipment. The magnetic core wire-layer goes an Angle according to the parameters set by the program

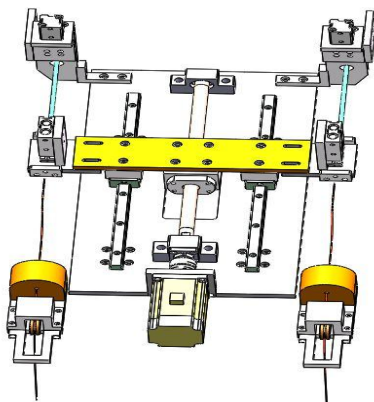

Double wire feeder

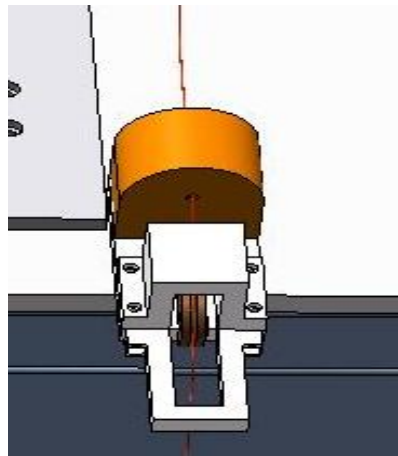

Enamelled wire shortage sensing system

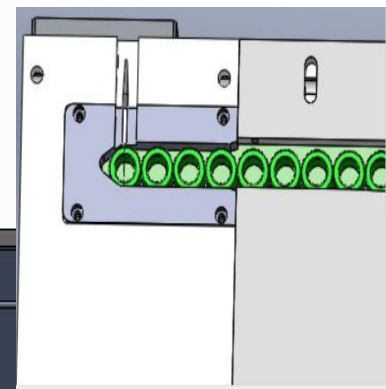

core shortage system

GREWIN INDUSTRIAL GROUP CO.,LTD.

Add: The fourth floor A-A3 zone aviation business area,Dongli Distr,Tianjin,China.



GREWIN INDUSTRIAL GROUP CO.,LTD.

TEL/WhatsApp: +86 18622096679

Mail: admin@coilwindingmachinechina.com

Web:www.coilwindingmachinechina.com



WhatsApp



WeChat

Line for the axial feeding, double wire feeding structure above the line to the core, to a fixed clamp to clamp after rising crochet hook line to pull down, send line after the completion of the pneumatic scissors drop wire feeding device back to the origin, after sending line length is set controller, the use of each product line length is set in advance, if the line finished using the lack of material conditions in the sensor will automatically alarm downtime, magnetic core, too.

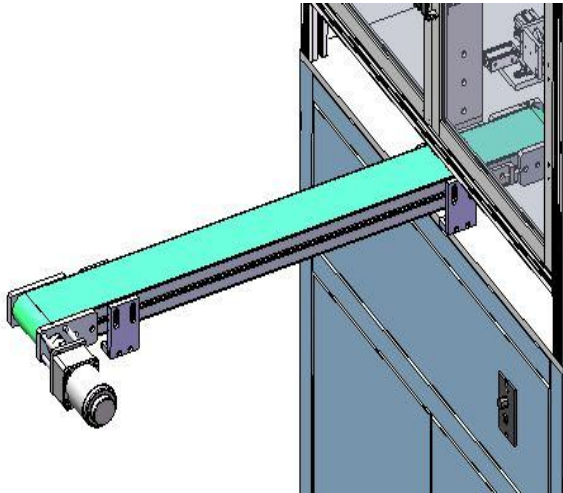

Unload the core transport tape

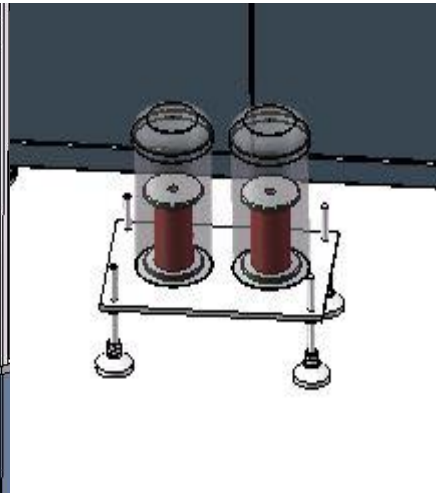

Bobbin stand

After winding, the product is directly sent to the transmission belt, which can be connected to the assembly line for the following process or directly into the storage basket. The bobbin is directly placed on the fixed mount, and the wire barrel is covered to prevent the wire from being damaged in contact with other objects

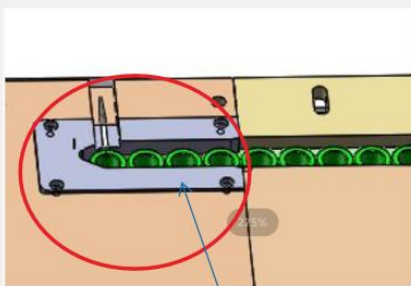

Replace the feeding guide block

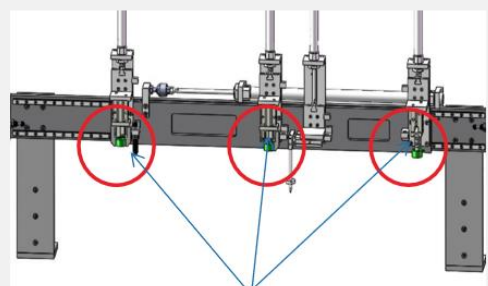

Replace three transplant clips

The commissioning time of new products is about: 40-70 minutes

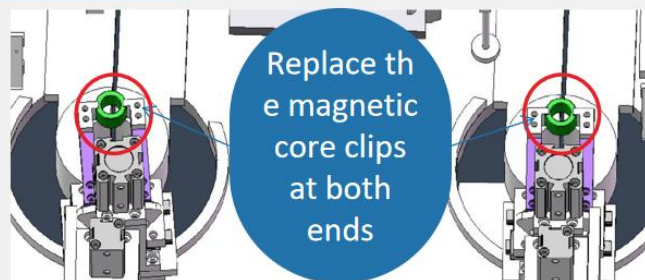

Replace the magnetic core clips at both ends

The conversion time of the existing program is 10-15 minutes

GREWIN INDUSTRIAL GROUP CO.,LTD.

Add: The fourth floor A-A3 zone aviation business area, Dongli Distr, Tianjin, China.



GREWIN INDUSTRIAL GROUP CO.,LTD.

TEL/WhatsApp: +86 18622096679

Mail: admin@coilwindingmachinechina.com

Web:www.coilwindingmachinechina.com



WhatsApp



WeChat

Scope of application



PACKAGING:

Packaging Material: Carton/Wooden case with foam inside.

1.General package(Paper carton or plastic bag): For small equipped parts for Multi Spindle Coil Winding

Machine , Package it with form and pack paper to guarantee unbroken during the transport.

2.Wooden case package: For larger scale Multi Spindle Coil Winding

Machine ,we have special skilled

carpenter, who would make the proper wooden case with exact thickness,density,length.

The up arrow ↑marked on the

outer wooden case. Buffer material would be put in the wooden case to prevent crack and shock.

GREWIN INDUSTRIAL GROUP CO.,LTD.

Add: The fourth floor A-A3 zone aviation business area,Dongli Distr,Tianjin,China.



GREWIN INDUSTRIAL GROUP CO.,LTD.

TEL/WhatsApp: +86 18622096679

Mail: admin@coilwindingmachinechina.com

Web:www.coilwindingmachinechina.com



WhatsApp



WeChat



FACTORY:

We-GREWIN INDUSTRIAL GROUP is expert in winding machines lines for 28Years. Our Grewin have ISO9001:2015,CE approvals,Machines'Patents,"high-tech enterprises"by the government.

From Japan and Taiwan

SUPER TECHNOLOGY AND BEST SPARE PARTS

- ✓ Fast High Quality Service
- ✓ Excellent Cost Performance

VIEW MORE >>

Whatsapp/Wechat: +8618322066726
E-mail: sales4@coilwindingmachinechina.com

GREWIN INDUSTRIAL GROUP CO.,LTD.

Add: The fourth floor A-A3 zone aviation business area,Dongli Distr,Tianjin,China.